

# LARGE ELECTRIC



8000 - 12000 LBS.

SPECIFICATIONS



7FBCU35-55

CLASS  
**1**

ELECTRIC MOTOR RIDERS

[ToyotaForklift.com](http://ToyotaForklift.com)

## LARGE ELECTRIC

CAPACITY  
**8000 - 12000 LBS.**

MAXIMUM FORK HEIGHT  
**239 IN.**

LOAD CENTER  
**24 IN.**

### INDUSTRIES



Beverage



Factory



Food Processing



Food Storage



General  
Manufacturing



General  
Warehousing



Retail

## STANDARD FEATURES

### SUPPORT

- System of Active Stability™ (SAS)
  - Active control rear stabilizer
  - Active Mast Control
- Operator Presence Sensing System (OPSS)
  - Key lowering interlock
  - Double-action parking brake
- Asbestos-free components
- Electric horn
- Manual return to neutral

### PERFORMANCE

- AC drive system (MOSFET Transistor)
- UL-approved model type “E”
- Three forms of energy regeneration
  - Coast control
  - Plug braking
  - Foot braking
- Load handling chopper
- Electronic hydraulic power steering
- Digital multifunction display
  - Time & date
  - Speedometer
  - Multifunction hour meter
  - Battery capacity indicator
  - Parking brake indicator
  - Overdischarge warning (lift interrupt)
  - Swing lock cylinder indicator
- Planetary drive axle
- Built-in analyzer
- Self-diagnostics
- Power select functions (S.P.H.)
- 3-way hydraulic control valve
- Auto shut-off (after 15 minutes)
- Travel power control (acceleration)

### BODY/EXTERIOR DESIGN

- Wide-view 2-stage mast (V)
- Punched plate entry/exit step
- 48" load backrest extension<sup>1</sup>
- 54" load backrest extension<sup>2</sup>
- Tapered forks
- Cushion tires (treaded)
- Wide-view carriage bars
- Drawbar pin
- Tie-down hooks
- Adjustable front headlights
- ORS vinyl non-suspension seat
- Retractable seatbelt
- 85° wide-opening battery hood
- Overhead guard
- SB 350 battery connector (gray)
- 39.2" battery compartment (8000 - 10000 lbs.)
- 45.7" battery compartment (12000 lbs.)

### OPERABILITY & ERGONOMICS

- Strategically configured instrument display
- Hydrostatic power steering
- Dual operator assist grips
- SAS automatic fork-leveling control
- Electric directional shift control
- Memory-tilt steering column
- Two-spoke steering wheel
- Cowl-mounted hydraulic controls
- Heavy-duty non-slip floor mat
- Dash-integrated pen/pencil holder
- Hood-integrated clipboard
- Dash-mounted cup holder

### SERVICEABILITY

- AC drive motor (no brushes or commutator)
- Easy-access hydraulic motor
- Bolt-on overhead guard
- Easy-access no tools required floorboard
- Battery compartment hood assist dampers
- Planned maintenance indicator
- Easy-access controller

<sup>1</sup> Standard on 7FBCU35-45.  
<sup>2</sup> Standard on 7FBCU55.

## OPTIONAL EQUIPMENT

### LOAD HANDLING

- Wide visible mast (V)
- Full free-lift 2-stage mast (FV)
- Full free-lift 3-stage mast (FSV)
- Tilt cylinder boots
- Tapered forks
- Fully tapered & polished forks
- Fork bar (wide carriage)
- High load backrest
- Side hosing termination
- Less mast & forks
- Less forks
- Less backrest

### LOAD HANDLING (HOSE & VALVE ASSEMBLY)

- 3-way valve (multiple options available)
- Cascade sideshifter
- 4-way valve (multiple options available)
- Hydraulic quick disconnects (dual)

### LIGHTS & INDICATORS

- Front combination lights
- LED front headlights
- Rear combination lights
- Rear working light
- LED work light
- Operator compartment light
- Strobe light (multiple options available)
- LED strobe light (multiple options available)
- Adjustable volume back up alarm (smart alarm)
- Back up chime
- Fire extinguisher (including bracket)
- Fire extinguisher 5 lb. upgrade (including bracket)

### BODY

- Rearview mirrors (left & right sides)
- Plastic mirrors
- Battery slide-out
- Battery compartment side panels
- Pencil/tape holder
- Keyless ignition
- 12-Volt power supply
- Anti-static strap
- Steering wheel with knob
- ORS semi-suspension seat (multiple options available)
- Vinyl ORS Araco seat (multiple options available)
- ORS 4-way adjustable seat (8 series style, multiple options available)
- Orange seatbelt
- Special paint (one or two color only)
- Cloth 20° swivel seat (requires option code G40C)
- Polycarbonate OHG cover
- Optional battery connector colors (multiple options available)

### CHASSIS

- Motor brush wear/overheat protection device
- Seat brake
- EZ Pedal (foot directional control)
- Wide tire & wide tread (front)
- French decals

### WHEELS & TIRES

- Treaded, non-marking tires (front & rear)
- Smooth tires (front & rear)
- Smooth, white, non-marking tires (front & rear)
- Smooth, non-marking tires (front & rear)

### SPECIAL MODEL

- UL-approved model
  - Type "EE"
  - Type "ES"
- Cold storage model
  - Type "20S"
- 48-Volt model

# TRUCK SPECIFICATIONS

## MODEL NUMBERS

GENERAL DATA				7FBCU35		7FBCU45		7FBCU55	
Load Capacity		lb (kg)		8000 (3500)		10000 (4500)		12000 (5500)	
Power Type (battery)	Voltage	V		36	48	36	48	36	48
Operator Position	Seated Rider				Seated Rider		Seated Rider		
Tire Type	Front / Rear	Cushion / Cushion				Cushion / Cushion		Cushion / Cushion	
Wheels (x = driven)	Front / Rear	2x / 2				2x / 2		2x / 2	
EXTERIOR DIMENSIONS				7FBCU35		7FBCU45		7FBCU55	
<b>A</b>	Maximum Fork Height (top of forks)	in (mm)		120 (3050)		120 (3050)		120.6 (3065)	
<b>B</b>	Free-Lift (top of forks)	in (mm)		4.3 (110)		4.3 (110)		4.9 (125)	
<b>C</b>	Fork Size (T x W x L)	in (mm)		2 x 6 x 42 (50 x 150 x 1070)		2 x 6 x 42 (50 x 150 x 1070)		2.6 x 6 x 48 (65 x 150 x 1220)	
<b>D</b>	Tilt Range (forward / backward)	deg		5 / 6		5 / 6		5 / 6	
<b>E</b>	Length to Fork Face	in (mm)		98.8 (2510)		103.5 (2630)		113 (2870)	
<b>F</b>	Overall Width	in (mm)		47.6 (1210)		53.1 (1350)		53.1 (1350)	
<b>G</b>	Mast Lowered Height	in (mm)		81.1 (2060)		83.0 (2110)		84.6 (2150)	
<b>H</b>	Mast Extended Height (top of load backrest)	in (mm)		168.1 (4270)		168.1 (4270)		174.6 (4435)	
<b>I</b>	Overhead Guard Height	in (mm)		91.9 (2330)		92.1 (2340)		95.3 (2420)	
<b>J</b>	Turning Radius (outside)	in (mm)		84.3 (2140)		87.6 (2225)		96.1 (2440)	
<b>K</b>	Load Distance <sup>1</sup>	in (mm)		18.3 (465)		19 (485)		20.9 (530)	
<b>L</b>	Basic Right-Angle Stacking Aisle Width <sup>2</sup>	in (mm)		102.6 (2605)		106.7 (2710)		116.9 (2970)	
PERFORMANCE DATA				7FBCU35		7FBCU45		7FBCU55	
				36V	48V	36V	48V	36V	48V
Speeds <sup>3</sup>	Maximum Travel (fwd. / rev.)	Full Load	mph (km/h)	8.4 (13.5)	10.9 (17.5)	7.8 (12.5)	10.9 (17.5)	7.5 (12)	9.0 (14.5)
		No Load	mph (km/h)	9.3 (15)	11.2 (18)	9.0 (14.5)	11.2 (18)	8.1 (13)	9.3 (15)
	Lifting	Full Load	fpm (mm/sec)	51.2 (260)	72.9 (370)	43 (220)	57 (290)	37 (190)	53 (265)
		No Load	fpm (mm/sec)	90.6 (460)	118.1 (600)	69 (350)	89 (450)	65 (330)	81 (405)
	Lowering	Full Load	fpm (mm/sec)	98 (500)		98 (500)		98 (500)	
		No Load	fpm (mm/sec)	108 (550)		98 (500)		108 (550)	
Drawbar Pull	Full Load / No Load	3-Min. Rating	lb (kg)	3800 (1720) / 3410 (1550)		3650 (1660) / 3280 (1490)		4780 (2170) / 4570 (2070)	
		3-Min. Rating	lb (kg)	3800 (1720) / 3410 (1550)		3650 (1660) / 3280 (1490)		4780 (2170) / 4570 (2070)	
		60-Min. Rating	lb (kg)	1860 (850) / 1980 (900)		1760 (800) / 1900 (860)		2320 (1050) / 2490 (1130)	
Gradeability <sup>*</sup>	Full Load / No Load	3-Min. Rating	%	16 / 22		13 / 18		14 / 20	
		3-Min. Rating	%	16 / 22		13 / 18		14 / 20	
		60-Min. Rating	%	7 / 13		5 / 10		6 / 11	
TRUCK WEIGHTS				7FBCU35		7FBCU45		7FBCU55	
Total Weight		lb (kg)		10450 (4740)		12570 (5695)		15010 (6805)	
Weight Distribution <sup>3</sup>	Full Load (front / rear)	lb (kg)		19350 (8535) / 2500 (1245)		22710 (10210) / 3460 (1620)		27460 (12515) / 3780 (1710)	
	No Load (front / rear)	lb (kg)		5820 (2640) / 8030 (3640)		5670 (2570) / 10500 (4760)		7730 (3505) / 11510 (5220)	
TIRES				7FBCU35		7FBCU45		7FBCU55	
Tires	Number (front / rear)			2 / 2		2 / 2		2 / 2	
	Size	Front		22 x 9 x 16		22 x 12 x 16		28 x 10 x 22	
Rear			18 x 6 x 12-1/8		18 x 7 x 12-1/8		18 x 8 x 12-1/8		
Wheelbase		in (mm)		61.2 (1555)		61.2 (1555)		69.7 (1770)	
Tread Width (front / rear)		in (mm)		38.6 (980) / 41.3 (1050)		41.1 (1045) / 42.4 (1080)		42.9 (1090) / 43.5 (1105)	
Underclearance (full load)	Minimum Mast	in (mm)		3.1 (80)		3.1 (80)		3.1 (80)	
	Center of Wheelbase	in (mm)		4.7 (120)		4.9 (125)		5.1 (130)	
Brake	Service (foot) / Parking Brake			Hydraulic / Hand		Hydraulic / Hand		Hydraulic / Hand	
POWER SYSTEM				7FBCU35		7FBCU45		7FBCU55	
				36V	48V	36V	48V	36V	48V
Battery	Voltage / Capacity (STD)	V / Ah		36 / 1360	48 / 1105	36 / 1360	48 / 1105	36 / 1700	48 / 1360
	6-Hour Ratings (high)	V / Ah		36 / 1760	48 / 1430	36 / 1760	48 / 1430	36 / 2200	48 / 1760
Electric Motors	Drive (dual)	kW		9.7 x 2	13.2 x 2	9.7 x 2	13.2 x 2	9.7 x 2	13.2 x 2
	Load Handling	kW		9.2	12.8	9.2	12.8	9.2	12.8
Control Type	Drive	Transistor Inverter				Transistor Inverter		Transistor Inverter	
	Load Handling	Transistor Chopper				Transistor Chopper		Transistor Chopper	
	Power Steering	Transistor Chopper				Transistor Chopper		Transistor Chopper	
Auxiliary Hydraulic Function Specifications (for attachments) <sup>4</sup>	Max. Operating Pressure	psi (kg/cm <sup>2</sup> )		2630 (185)		2630 (185)		2630 (185)	
	Max. Flow Rate with Chopper	gpm (lpm)		Please contact your local, authorized Toyota dealer for information.					

\* Computed values.

1 At centerline of front axle to front face of forks.  
2 Add load length & clearance.

3 With standard battery.

4 Values taken at Hydraulic Control Valve. Does not take in to consideration losses through mast plumbing (hosing, fittings, QDs, etc.).

# EXTERIOR DIMENSIONS

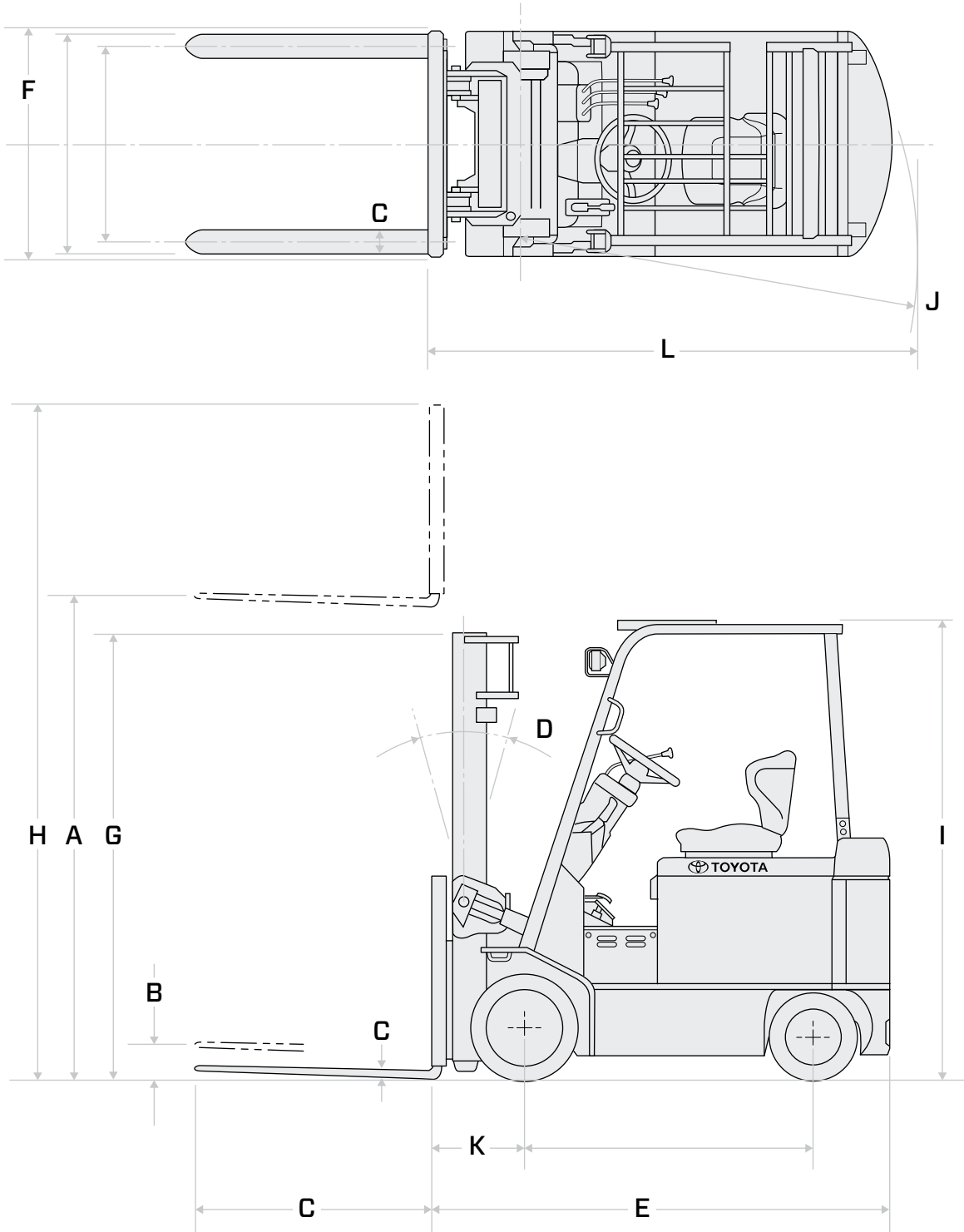

# MAST SPECIFICATIONS

MAST TYPE	MAXIMUM FORK HEIGHT (TOP OF FORKS)	OVERALL HEIGHT			FREE-LIFT		SINGLE TIRE				
		LOWERED	EXTENDED		WITHOUT LOAD BACKREST	WITH STANDARD LOAD BACKREST <sup>1</sup>	TILT RANGE		LOAD CAPACITY AT 24 IN. (600 MM) LOAD CENTER		
			WITHOUT LOAD BACKREST	WITH STANDARD LOAD BACKREST <sup>1</sup>			FWD	BWD	NARROW TREAD	WIDE TREAD	
		in (mm)	in (mm)	in (mm)	in (mm)	in (mm)	in (mm)	deg	deg	lb (kg)	lb (kg)
<b>7FBCU35</b>											
Wide Visible (V)	120 (3050)	81.1 (2060)	149.6 (3800)	168.1 (4270)	4.3 (110)	4.3 (110)	5	6	8000 (3500)	8000 (3500)	
	132 (3350)	88.2 (2240)	161.4 (4100)	179.9 (4570)	4.3 (110)	4.3 (110)	5	6	8000 (3500)	8000 (3500)	
	140 (3550)	92.1 (2340)	169.3 (4300)	187.8 (4770)	4.3 (110)	4.3 (110)	5	6	8000 (3500)	8000 (3500)	
	147.5 (3750)	96.1 (2440)	177.2 (4500)	195.7 (4970)	4.3 (110)	4.3 (110)	5	6	8000 (3500)	8000 (3500)	
	179 (4550)	115.8 (2940)	208.7 (5300)	227.2 (5770)	4.3 (110)	4.3 (110)	5	6	8000 (3500)	8000 (3500)	
Full Free-Lift 2-Stage (FV)	120 (3050)	81.1 (2060)	150.8 (3830)	168.1 (4270)	50.4 (1280)	33.1 (840)	5	6	8000 (3500)	8000 (3500)	
	132 (3350)	88.2 (2240)	162.6 (4130)	179.9 (4570)	57.5 (1460)	40.2 (1020)	5	6	8000 (3500)	8000 (3500)	
Full Free-Lift 3-Stage (FSV)	159.5 (4050)	76.4 (1940)	190.9 (4850)	207.5 (5270)	44.9 (1140)	28.4 (720)	5	5	8000 (3500)	8000 (3500)	
	171.5 (4350)	81.1 (2060)	202.8 (5150)	219.3 (5570)	49.6 (1260)	33.1 (840)	5	5	8000 (3500)	8000 (3500)	
	187 (4750)	88.2 (2240)	218.5 (5550)	235 (5970)	56.7 (1440)	40.2 (1020)	5	5	8000 (3500)	8000 (3500)	
	199 (5050)	92.1 (2340)	230.3 (5850)	246.9 (6270)	60.6 (1540)	44.1 (1120)	5	5	7730 (3500)	7730 (3500)	
	218.5 (5550)	98 (2490)	250 (6350)	266.5 (6770)	66.5 (1690)	50 (1270)	5	5	7470 (3400) <sup>2</sup>	7470 (3400) <sup>3</sup>	
	238 (6050)	105.9 (2690)	269.7 (6850)	286.2 (7270)	74.4 (1890)	57.9 (1470)	5	5	N/A	7000 (3150) <sup>3</sup>	

MAST TYPE	MAXIMUM FORK HEIGHT (TOP OF FORKS)	OVERALL HEIGHT			FREE-LIFT		SINGLE TIRE				
		LOWERED	EXTENDED		WITHOUT LOAD BACKREST	WITH STANDARD LOAD BACKREST <sup>1</sup>	TILT RANGE		LOAD CAPACITY AT 24 IN. (600 MM) LOAD CENTER		
			WITHOUT LOAD BACKREST	WITH STANDARD LOAD BACKREST <sup>1</sup>			FWD	BWD	NARROW TREAD	WIDE TREAD	
		in (mm)	in (mm)	in (mm)	in (mm)	in (mm)	in (mm)	deg	deg	lb (kg)	lb (kg)
<b>7FBCU45</b>											
Wide Visible (V)	120 (3050)	83.1 (2110)	152 (3860)	168.1 (4270)	4.3 (110)	4.3 (110)	5	6	10000 (4500)	N/A	
	132 (3350)	92.1 (2340)	163.8 (4160)	179.9 (4570)	4.3 (110)	4.3 (110)	5	6	10000 (4500)	N/A	
	140 (3550)	96.1 (2440)	171.7 (4360)	187.8 (4770)	4.3 (110)	4.3 (110)	5	6	10000 (4500)	N/A	
	147.5 (3750)	100 (2540)	179.5 (4560)	195.7 (4970)	4.3 (110)	4.3 (110)	5	6	10000 (4500)	N/A	
	179 (4550)	115.8 (2940)	211 (5360)	227.2 (5770)	4.3 (110)	4.3 (110)	5	6	10000 (4500)	N/A	
Full Free-Lift 2-Stage (FV)	120 (3050)	83.1 (2110)	152.2 (3865)	168.1 (4270)	51 (1295)	35 (890)	5	6	10000 (4500)	N/A	
	132 (3350)	92.1 (2340)	164 (4165)	179.9 (4570)	60 (1525)	44.1 (1120)	5	6	10000 (4500)	N/A	
Full Free-Lift 3-Stage (FSV)	159.5 (4050)	81.1 (2060)	191.5 (4865)	207.5 (5270)	49 (1245)	33.1 (840)	5	5	10000 (4500)	N/A	
	171.5 (4350)	85.6 (2175)	203.4 (5165)	219.3 (5570)	53.5 (1360)	37.6 (955)	5	5	10000 (4500)	N/A	
	187 (4750)	92.1 (2340)	219.1 (5565)	235 (5970)	60 (1525)	44.1 (1120)	5	5	10000 (4500)	N/A	
	199 (5050)	98 (2490)	230.9 (5865)	246.9 (6270)	65.9 (1675)	50 (1270)	5	5	10000 (4400)	N/A	
	218.5 (5550)	105.9 (2690)	250.6 (6365)	266.5 (6770)	73.8 (1875)	57.9 (1470)	5	5	9650 (4250)	N/A	
	238 (6050)	115.8 (2940)	270.3 (6865)	286.2 (7270)	83.7 (2125)	67.7 (1720)	5	5	9000 (4110)	N/A	

MAST TYPE	MAXIMUM FORK HEIGHT (TOP OF FORKS)	OVERALL HEIGHT			FREE-LIFT		SINGLE TIRE				
		LOWERED	EXTENDED		WITHOUT LOAD BACKREST	WITH STANDARD LOAD BACKREST <sup>1</sup>	TILT RANGE		LOAD CAPACITY AT 24 IN. (600 MM) LOAD CENTER		
			WITHOUT LOAD BACKREST	WITH STANDARD LOAD BACKREST <sup>1</sup>			FWD	BWD	NARROW TREAD	WIDE TREAD	
		in (mm)	in (mm)	in (mm)	in (mm)	in (mm)	in (mm)	deg	deg	lb (kg)	lb (kg)
<b>7FBCU55</b>											
Wide Visible (V)	120.5 (3065)	84.7 (2150)	150.6 (3825)	174.6 (4435)	4.9 (125)	4.9 (125)	5	6	12000 (5500)	N/A	
	132.5 (3365)	90.6 (2300)	162.4 (4125)	186.4 (4735)	4.9 (125)	4.9 (125)	5	6	12000 (5500)	N/A	
	140.5 (3565)	94.5 (2400)	170.3 (4325)	194.3 (4935)	4.9 (125)	4.9 (125)	5	6	12000 (5500)	N/A	
	148 (3765)	100.4 (2550)	178.2 (4525)	202.2 (5135)	4.9 (125)	4.9 (125)	5	6	12000 (5500)	N/A	
	179.5 (4565)	118.1 (3000)	209.7 (3525)	233.7 (5935)	4.9 (125)	4.9 (125)	5	6	12000 (5500)	N/A	
Full Free-Lift 3-Stage (FSV)	160 (4065)	81.5 (2070)	187.8 (4770)	214 (5435)	53.7 (1365)	27.6 (700)	5	6	12000 (5500)	N/A	
	172 (4365)	84.7 (2150)	199.6 (5070)	225.8 (5735)	56.9 (1445)	30.7 (780)	5	6	12000 (5500)	N/A	
	187.5 (4765)	90.6 (2300)	215.4 (5470)	241.5 (6135)	62.8 (1595)	36.6 (930)	5	6	12000 (5500)	N/A	
	199.5 (5065)	94.5 (2400)	227.2 (5770)	253.4 (6435)	66.7 (1695)	40.6 (1030)	5	6	11800 (5350)	N/A	
	219 (5565)	100.4 (2550)	246.9 (6270)	273 (6935)	72.6 (1845)	46.5 (1180)	5	6	10900 (5000)	N/A	
	239 (6065)	108.3 (2750)	266.5 (6770)	292.7 (7435)	80.5 (2045)	54.3 (1380)	5	6	10000 (4550)	N/A	

1 Height of standard load backrest is 48" (1220 mm).  
 2 Available as a TSDR only & subject to TIEM review.  
 3 Requires option GOOG Wide Axle/Wide Tread.



AISLE  
**15**

TOYOTA

TOYOTA

TOYOTA



# “I’M HERE TO MAKE SURE YOUR FORKLIFTS DON’T TAKE VACATION DAYS.”

Butch – 360 Technician, ProLift, Cincinnati, Ohio



## HELP IS ALWAYS HERE WITH TOYOTA 360 SUPPORT.

The industry’s best and most comprehensive dealer network quickly delivers Toyota Certified Technicians to your work site. These specially-trained technicians can also help assess your warehouse and facility needs to recommend the right equipment for the job. And with the largest fleet of used and rental forklifts, Toyota 360 keeps your business running at full speed.

[ToyotaForklift.com/360-Support](http://ToyotaForklift.com/360-Support)



**YOUR BUSINESS IS RIDING ON IT.**

Some product features described herein are optional. Please consult your dealer for specifications. Details of specifications and equipment are based on information available at time of printing and may change without notice.

