

Technical sheet :

TMT 55 XT



Technical characteristics			Metric	Imperial
1.1	Manufacturer		Manitou	Manitou
1.2	Model Name		TMT 55 XT	TMT 55 XT
1.2.1	Reach out equipment		Telescopic boom	Telescopic boom
1.3	Power source		Diesel	Diesel
1.4	Operator type		Seated	Seated
1.5	Max. capacity	Q	2500 kg	5512 lbs
Weight				
2.1	Service Weight		2660 kg	5864 lbs
Wheels				
3.2	Dimensions of front wheels		31 x 15,5 - 15"	31 x 15,5 - 15"
3.3	Dimensions of rear wheels		31 x 15,5 - 15"	31 x 15,5 - 15"
3.5	Number of front wheels / rear wheels		2 / 1	2 / 1
3.5.1	Drive wheels (front / rear)		2 / 1	2 / 1
Dimensions				
4.4	Max. lifting height	h3	3430 mm	11 ft 3 in
4.5	Height telescopic boom extended	h4	3915 mm	12 ft 10 in
4.20	Length to face of forks	l2	2.85 m	9 ft 4 in
4.21	Overall width	b1	2.57 m	8 ft 5 in
4.22	Forks section / width / length	s / e / l	44 mm x 102 mm x 1219 mm	2 in x 4 in x 4 ft
4.28	Max. Reach	l4	1310 mm	4 ft 4 in
4.35	Turning radius	Wa	274 m	898 ft 11 in
Performances				
5.1	Travel speed (laden)		11 km/h	6.8 mph
5.10	Service brake		Hydrostatic	Hydrostatic
5.11	Transmission type		Hydrostatic	Hydrostatic
Engine				
7.1	Engine brand / norm		Kubota - Tier IV Final	Kubota - Tier IV Final
7.4	Capacity of cylinders		2434 cm ³	148.53 in ³
7.3	Rated speed		2700 tr/min	2700 tr/min
7.2	Engine power according to ISO 1585		37 kW	37 kW
Miscellaneous				
8.2	Working hydraulic pressure for attachments (bar)		245 Bar	17 PSI
8.3	Oil flow rate for attachments		46 l/min	46 l/min

Dimensional drawing

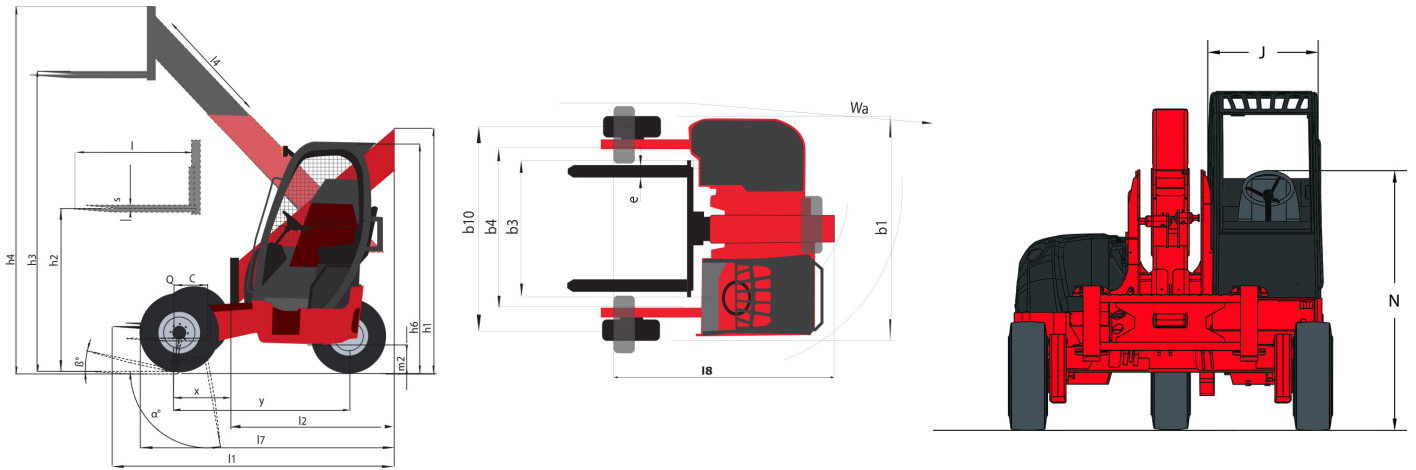

Load chart

Machine on stabilizers with forks Metric

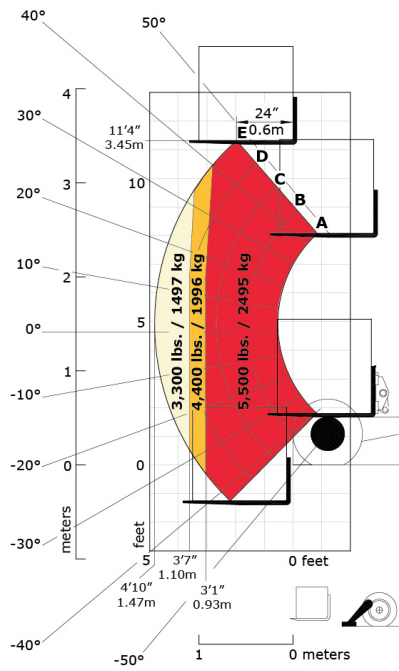

Machine on tyres with forks Metric

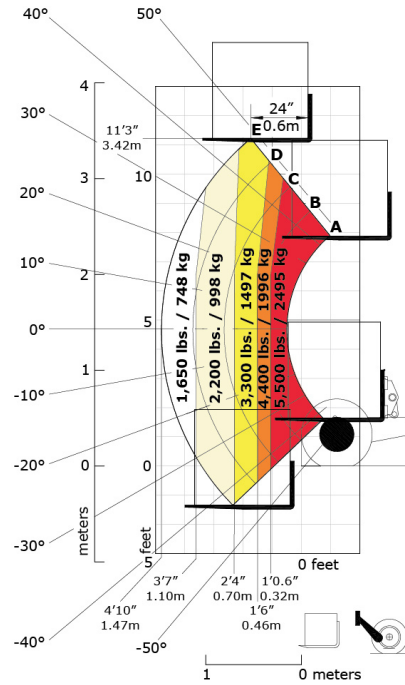



Siège Social
430 rue de l'Aubinière - 44150 Ancenis Cedex - France
Tel: +33(0)2 40 09 10 11 - Fax: +33 (0)2 40 09 10 97
www.manitou.com



This brochure describes versions and configuration options for Manitou products which may be fitted with different equipment. The equipment described in this brochure may be standard, optional or not available depending on version. Manitou reserves the right to change the specifications shown and described at any time and without prior warning. The manufacturer is not liable for the specifications given. For more information, contact your Manitou dealer. Non-contractual document. Product descriptions may differ from actual products. List of specifications is not comprehensive. The logos and visual identity of the company are the property of Manitou and may not be used without authorisation. All rights reserved. The photos and diagrams contained in this brochure are provided for information only.

MANITOU BF SA - Limited company with board of directors - Share capital: 39,547,824 euros - 857 802 508
RCS Nantes